

FOR 8" DIA. AND SMALLER WATER MAIN

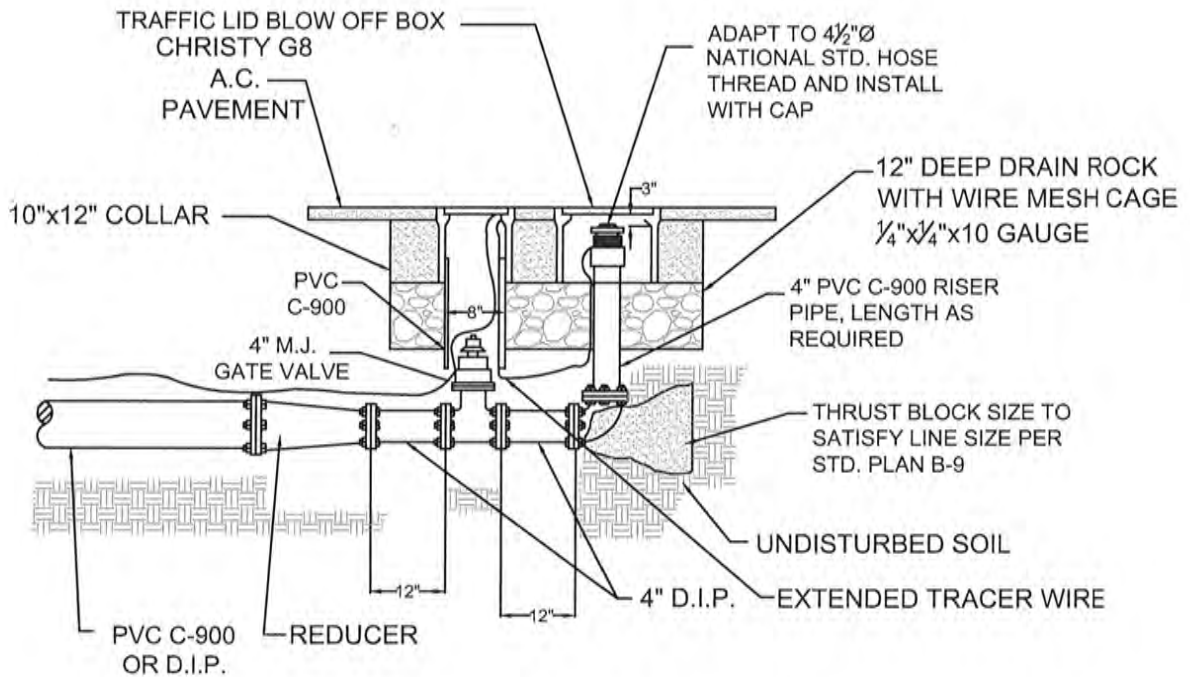

FOR 10" DIA. AND LARGER WATER MAIN

TITLE: **BLOW OFF ASSEMBLY**

DRAWN BY: STAFF	SCALE: NONE
REVIEWED BY: DANNY HILLSTOCK	REVISED: OCTOBER, 2019
CITY OF HOLLISTER ENGINEERING DEPARTMENT	

APPROVED: <i>Danny Hillstock</i> CITY ENGINEER: DANNY HILLSTOCK, LIC. NO. 70647	DATE: 11-5-19
---	------------------

STANDARD PLAN B-8 SHEET 1 OF 1
