

CASE I-PLANTER @ CURB

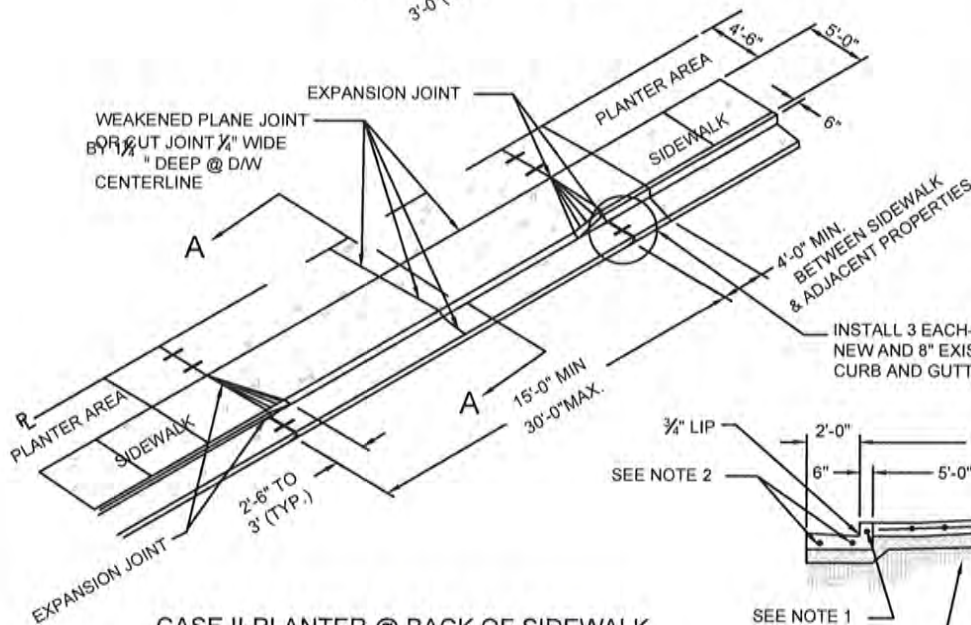

CASE II-PLANTER @ BACK OF SIDEWALK

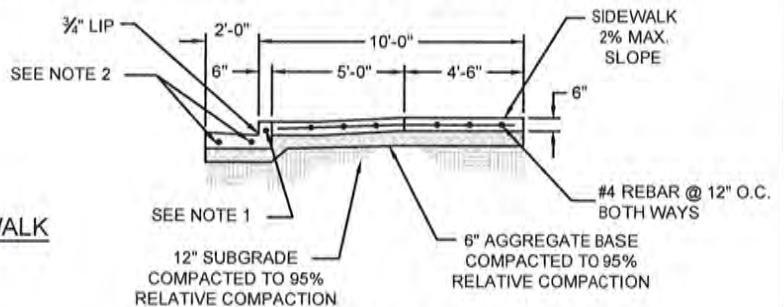

SECTION A-A

NOTES:

1. WHEN APPROACH AND GUTTER ARE PLACED SEPARATELY, USE #4 x 32" REBAR AT 24" OC.
2. INSTALL REBAR DOWELS FROM EXISTING CURB AND GUTTER TO NEW CURB AND GUTTER AS SHOWN ABOVE.
3. CONCRETE TO HAVE LIGHT BROOM FINISH PERPENDICULAR TO STREET AND TREATED WITH CURING COMPOUND.
4. MAXIMUM FRONTAGE OCCUPIED BY DRIVEWAY OR COMBINATION OF DRIVEWAYS IS 40%, EXCLUDING CUL-DE-SAC.
5. MINIMUM 18' DISTANCE BETWEEN DRIVEWAYS ON FRONTAGE OF PROPERTY.
6. FIRE HYDRANTS SHALL BE 10' MINIMUM FROM DRIVEWAYS. SEE B-1-2.

TITLE: RESIDENTIAL DRIVEWAY APPROACH AND SIDEWALK

DRAWN BY:
STAFF

SCALE:
NONE

APPROVED:

STANDARD PLAN

REVIEWED BY:
DANNY HILLSTOCK

REVISED:
OCTOBER, 2019

Danny Hillstock 11-5-19

A-10

CITY OF HOLLISTER
ENGINEERING DEPARTMENT

CITY ENGINEER: DANNY HILLSTOCK, INC. NO. 00647 DATE

SHEET 1 OF 1